

AUDIO MASTER®

6 / 8 / 12 / 16 CHANNEL LIVE MIXER

USER'S MANUAL

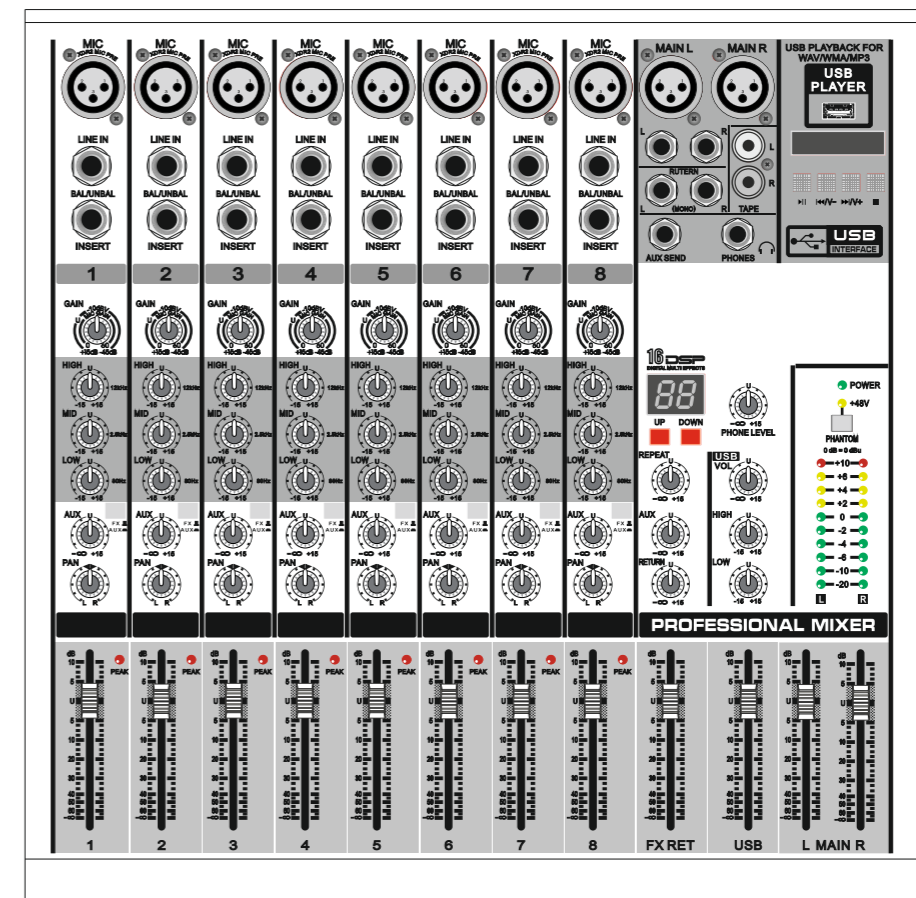

MG SERIES

PROFESSIONAL
POWERED MIXING SERIES

PROFESSIONAL MIXING CONSOLE

Contents

Contents	1
IMPORTANT SAFETY INSTRUCTIONS	2
Read This Page!	3
Patchbay Description	
E-Z INTERFACING	4
1. MIC INPUTS	4
PHANTOM POWER	4
2. LINE INPUTS	5
3. PHONES	5
4. AUX SEND	5
5. AUX RETURNS	5
6. TAPE OUTPUT/REC	5
7. MP3 PLAYER	5
8. MAIN OUTPUTS	5
9. POWER SWITCH	6
10. POWER CONNECTION	6
Channel Strip Description	
"U" LIKE UNITY GAIN.....	6
11. GAIN	6
12. HI EQ	7
13. MID EQ	7
14. LOW EQ	7
15. AUX / FX	8
16. AUX	8
17. PAN	8
18. PEAK(PEAK LEVEL INDICATOR)	8
19. CHANNEL FADER	8

Master Controls Description	
20. POWER LED	8
21. PHANTOM POWER SWITCH	8
22. METERS	9
23. PHONES LEVEL	9
24.USB PLAYER CHANNEL	9
25. USB FADER.....	9
26. DISPLAY	9
27. REPEAT	9
28. AUX SEND	9
29. AUX RETURN	9
30. FX RETURN FADER.....	9
31. LEFT / RIGHT MAIN FADER.....	9

Block Diagram.....	10
--------------------	----

Appendix A: Connections	
"XLR" Connectors.....	11
1/4" TRS Phone Plugs and Jacks.....	11
1/4" TS Phone Plugs and Jacks.....	11
Switched 1/4" Phone Jacks.....	11
RCA Plugs and Jacks.....	12
Unbalancing a Line.....	12
TRS Send/Receive Insert Jacks.....	12
Using the Send Only on an Insert Jack	12
stereo Input and returns :	
Mono, Stereo, Whatever.....	13

Appendix B: Technical Information	
Specifications.....	14

Appendix B: Technical Information Specifications

Main Mix Noise	
(20 Hz- 20 kHz bandwidth, 1/4" Main out, channel gains @ unity gain, channel EQs flat, all channels assigned to Main Mix, odd channels panned left, even channels panned right.)	
Main Mix fader unity, channel faders down:	-86.5 dBu
(90 dB Signal to Noise Ratio, ref +4 dBu)	
Main Mix fader unity, channel faders @ unity:	-86 dBu

Total Harmonic Distortion (THD)	
(1 kHz 35 dB gain, 20 Hz-20 kHz bandwidth)	
Mic in to insert out:	<0.0007%

Attenuation (Crosstalk)	
(1 kHz relative to 0 dBu, 20 Hz-20 kHz bandwidth, Line in, 1/4" Main Out, Gain @ unity.)	
Channel Mute switch engaged:	-82 dBu
Channel Gain knob down:	-82 dBu

Frequency Response	
(Mic input to any output.)	
20 Hz to 40 kHz:	+0 dB/-1 dB
20 Hz to 60 kHz:	+0 dB/-3 dB

Equivalent Input Noise (EIN)	
(Mic in to Insert Send out, max gain.)	
150 ohm termination:	-129.5 dBu 20 Hz-20 kHz

Common Mode Rejection Ratio (CMRR)	
(Mic in to Insert Send out, max gain.)	
1 kHz:	better than -70 dB

Maximum Levels	
Mic in:	+22 dBu
All other inputs:	+22 dBu
Main Mix TRS out and XLR out:	+28 dBu
All other outputs:	+22 dBu

Impedances	
Mic in:	2.5 kilohms
Channel Insert return:	2.5 kilohms
All other inputs:	10 kilohms or greater
Tape out:	1.1 kilohms
All other outputs:	120 ohms

3 Band EQ	
High Shelving	±15 db @ 12 kHz
Mid Peaking	±15 dB sweep 100 Hz- 8 kHz
Low Shelving	±15 db @ 80 Hz
Low Cut Filter	18 dB/octave, -3 dB @ 75 Hz

Power Consumption	
120/240 VAC, 50/60 Hz, 50 watts	
Fuse Ratings	
100-120 VAC	1A Slo Blo, 5 x 20 mm
220-240 VAC	0.5A Slo Blo, 5 x 20 mm

Important Safety Instructions

Stereo Inputs and Returns: Mono, Stereo, Whatever

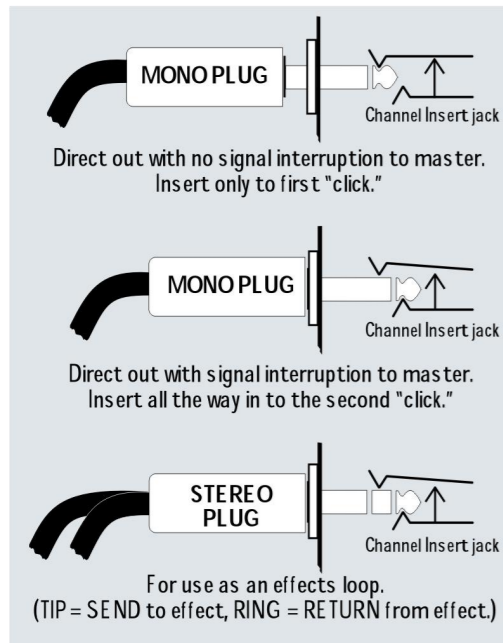

Figure F

Stereo line inputs and stereo returns are a fine example of the philosophy (which we just made up) of Maximum Flexibility with Minimum Headache. The inputs and returns will automatically be mono or stereo, depending upon how you use the jacks. Here's how it works:

A mono signal should be patched into the input or return jack labeled Left (MONO). The signal will be routed to both the left and right sides of the return circuit, and will show up in the center of the stereo pair of buses it's assigned to, or it can be panned with the PAN control.

A stereo signal, having two plugs, should be patched into the LEFT (MONO) and the RIGHT input or return jacks. A jack switch in the RIGHT jack will disable the mono function, and the signals will show up in stereo.

A mono signal connected to the RIGHT jack will show up in the right bus only. You probably will only want to use this sophisticated effect for special occasions.

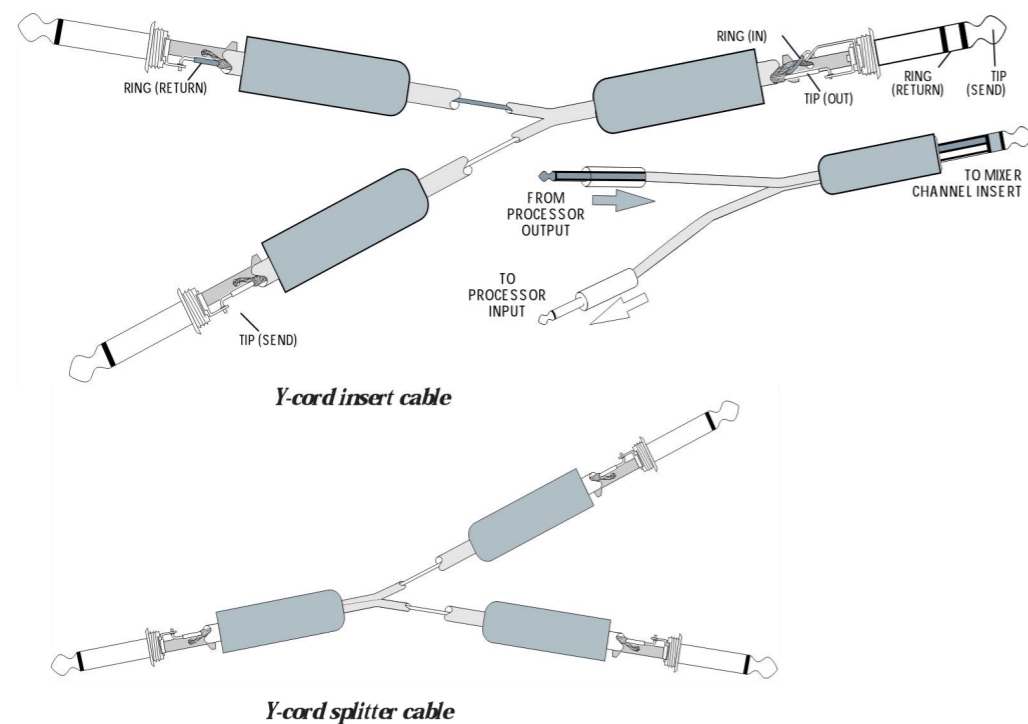

1. Read these instructions.
2. Keep these instructions.
3. Heed all warnings.
4. Follow all instructions.
5. Do not use this apparatus near water.
6. Clean only with a dry cloth.
7. Do not block any ventilation openings. Install in accordance with the manufacturer's instructions.
8. Do not install near any heat sources such as radiators, heat registers, stoves, or other apparatus (including amplifiers) that produce heat.
9. Do not defeat the safety purpose of the polarized or grounding-type plug. A polarized plug has two blades with one wider than the other. A grounding-type plug has two blades and a third grounding prong. The wide blade or the third prong are provided for your safety. If the provided plug does not fit into your outlet, consult an electrician for replacement of the obsolete outlet.
10. Protect the power cord from being walked on or pinched particularly at plugs, convenience receptacles, and the point where they exit from the apparatus.
11. Only use attachments/ accessories specified by the manufacturer.
12. Use only with a cart, stand, tripod, bracket, or table specified by the manufacturer, or sold with the apparatus. When a cart is used, use caution when moving the cart/ apparatus combination to avoid injury from tip-over.

13. Unplug this apparatus during lightning storms or when unused for long periods of time.
14. Refer all servicing to qualified service personnel. Servicing is required when the apparatus has been damaged in any way, such as power-supply cord or plug is damaged, liquid has been spilled or objects have fallen into the apparatus, the apparatus has been exposed to rain or moisture, does not operate normally, or has been dropped.
15. This apparatus shall not be exposed to dripping or splashing, and no object filled with liquids, such as vases or beer glasses, shall be placed on the apparatus.
16. This apparatus has been designed with Class-I construction and must be connected to a mains socket outlet with a protective earthing connection (the third grounding prong).
17. This apparatus has been equipped with an all-pole, rocker-style AC mains power switch. This switch is located on the rear panel and should remain readily accessible to the user.

PORTABLE CART WARNING

Carts and stands - The Component should be used only with a cart or stand that is recommended by the manufacturer. A Component and cart combination should be moved with care. Quick stops, excessive force, and uneven surfaces may cause the Component and cart combination to overturn.

Duration Per Day In Hours	Sound Level dBA, Slow Response	Typical Example
8	90	Duo in small club
6	92	
4	95	Subway Train
3	97	
2	100	Very loud classical music
1.5	102	
1	105	Dave screaming at Steve about deadlines
0.5	110	
0.25 or less	115	Loudest parts at a rock concert

WARNING — To reduce the risk of fire or electric shock, do not expose this apparatus to rain or moisture.

CAUTION AVIS

RISK OF ELECTRIC SHOCK
DO NOT OPEN
RISQUE DE CHOC ELECTRIQUE
NE PAS OUVRIR

CAUTION: TO REDUCE THE RISK OF ELECTRIC SHOCK DO NOT REMOVE COVER (OR BACK) NO USER-SERVICEABLE PARTS INSIDE REFER SERVICING TO QUALIFIED PERSONNEL

ATTENTION: POUR EVITER LES RISQUES DE CHOC ELECTRIQUE, NE PAS ENLEVER LE COUVERCLE. AUCUN ENTRETIEN DE PIECES INTERIEURES PAR L'USAGER. CONFIER

- The lightning flash with arrowhead symbol within an equilateral triangle is intended to alert the user to the presence of uninsulated "dangerous voltage" within the product's enclosure, that may be of sufficient magnitude to constitute a risk of electric shock to persons.
- The exclamation point within an equilateral triangle is intended to alert the user of the presence of important operating and maintenance (servicing) instructions in the literature accompanying the appliance.

Read This Page!

We realize that you must have a powerful hankerin' to try out the mixer or you might be one of those people who never reads manuals. All we ask is that you read this page NOW, and read the rest later—you'll be glad you did.

Level-Setting Procedure

Message to seasoned pros: do NOT set levels using the old "Turn the trim up until the clip light comes on, then back off a hair" trick. When a the mixer clip light comes on, you really are about to clip.

This procedure really works — it assures low noise and high headroom. Please read on.

It's not even necessary to hear what you're doing to set optimal levels. But if you'd like to: Plug headphones into the PHONES output jack, then set the PHONES knob about one-quarter of the way up.

The following steps must be performed one channel at a time:

1. Turn the GAIN, MON, FX send and fader controls fully down.
2. Set all the EQ knobs at the center detents.
3. Connect the signal source to the MIC or LINE channel input.
4. Engage (push in) the channel's PFL switch.
5. Play something into the selected input, at real-world levels.
6. Adjust the GAIN control so that the display on the meter stays around "0." (Only the left meter is active in the Level-Setting Procedure.)
7. If you'd like to apply some EQ, do so now and return.
8. Disengage that channel's PFL switch.
9. Repeat for each channel.

Other Nuggets of Wisdom

For optimum sonic performance, the channel faders and the MAIN MIX fader should be set near the "U" (unity gain) markings.

Always turn down the MAIN MIX fader knobs before making connections to your mixer, or turning PHANTOM POWER on.

If you shut down your equipment, turn off your amplifiers first. When powering up, turn them on last.

Save the shipping box! You may need it someday.

Instant Mixing

Here's how to get going right away, using a microphone and a keyboard:

1. Plug your microphone into Channel 1's MIC input.
2. Perform the Level-Setting Procedure.
3. Connect cords from the MAIN OUT jacks to your amplifier.
4. Hook up speakers to the amp and turn it on.
5. Set channel 1's fader to the "U" mark.
6. Engage (push in) Channel 1's L/R switch.
7. Set the MAIN MIX fader one-quarter of the way up.
8. Sing like a canary!
9. Plug your keyboard into channels 3 and 4.
10. Turn channel 3's PAN knob fully left and channel 4's PAN knob fully right.
11. Set those faders to the "U" mark.
12. Perform the Level-Setting Procedure.
13. Engage the L/R switch on these channels.
14. Play like a madman and sing like a canary!

RCA Plugs and Jacks

RCA-type plugs (also known as phono plugs) and jacks are often used in home stereo and video equipment and in many other applications (Figure D). They are unbalanced and electrically identical to a 1/4" TS phone plug or jack. See Figure C. Connect the signal to the center post and the ground (earth) or shield to the surrounding "basket."

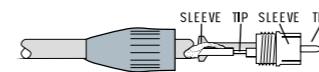

Figure D: RCA Plug

Unbalancing a Line

In most studio, stage and sound reinforcement situations, there is a combination of balanced and unbalanced inputs and outputs on the various pieces of equipment. This usually will not be a problem in making connections.

- When connecting a balanced output to an unbalanced input, be sure the signal high (hot) connections are wired to each other, and that the balanced signal low (cold) goes to the ground (earth) connection at the unbalanced input. In most cases, the balanced ground (earth) will also be connected to the ground (earth) at the unbalanced input. If there are ground-loop problems, this connection may be left disconnected at the balanced end.
- When connecting an unbalanced output to a balanced input, be sure that the signal high (hot) connections are wired to each other. The unbalanced ground (earth) connection should be wired to the low (cold) and the ground (earth) connections of the balanced input. If there are ground-loop problems, try connecting the unbalanced ground (earth) connection only to the input low (cold) connection, and leaving the input ground (earth) connection disconnected.
- In some cases, you will have to make up special adapters to interconnect your equipment. For example, you may need a balanced XLR female connected to an unbalanced 1/4" TS phone plug.

TRS Send/Receive Insert Jacks

The single-jack inserts are the three-conductor, TRS-type 1/4" phone. They are unbalanced, but have both the mixer output (send) and the mixer input (return) signals in one connector. See Figure E.

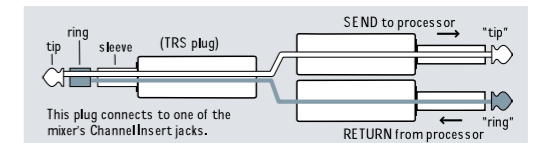

Figure E

The sleeve is the common ground (earth) for both signals. The send from the mixer to the external unit is carried on the tip, and the return from the unit to the mixer is on the ring.

Using the Send Only on an Insert Jack

If you insert a TS (mono) 1/4" plug only partially (to the first click) into an insert jack, the plug will not activate the jack switch and will not open the insert loop in the circuit (thereby allowing the channel signal to continue on its merry way through the mixer).

This allows you to tap out the channel or bus signal without interrupting normal operation.

If you push the 1/4" TS plug in to the second click, you will open the jack switch and create a direct out, which does interrupt the signal in that channel. See Figure F on the next page.

NOTE: Do not overload or short-circuit the signal you are tapping from the mixer. That will affect the internal signal.

Appendix A: Connections

"XLR" Connectors

The mixers use 3-pin female "XLR" connectors on all microphone inputs, with pin 1 wired to the grounded (earthed) shield, pin 2 wired to the "high" ("hot" or positive polarity) side of the audio signal and pin 3 wired to the "low" ("cold" or negative polarity) side of the signal. See Figure A. This is all totally aboveboard and in full accord with the hallowed standards dictated by the AES (Audio Engineering Society).

Use a male "XLR"-type connector, usually found on the nether end of what is called a "mic cable," to connect to a female XLR jack.

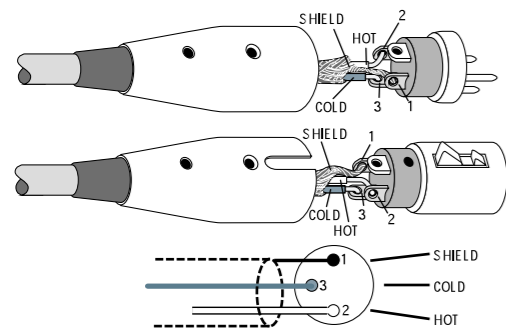

Figure A: XLR Connectors

1/4" TRS Phone Plugs and Jacks

"TRS" stands for Tip-Ring-Sleeve, the three connections available on a "stereo" 1/4" or "balanced" phone jack or plug. See Figure B.

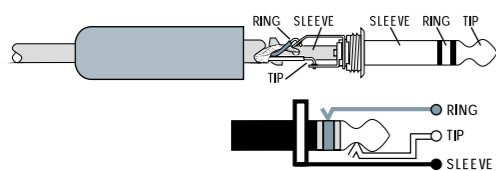

Figure B: "TRS Plugs

TRS jacks and plugs are used in several different applications:

- Stereo Headphones, and rarely, stereo microphones and stereo line connections. When wired for stereo, a 1/4" TRS jack or plug is connected tip to left, ring to right and sleeve to ground (earth). The mixers do not directly accept 1-plug-type stereo microphones. They must be separated into a left cord and a right cord, which are plugged into the two mic preamps.

You can cook up your own adapter for a stereo microphone adapter. "Y" two cables out of a female 1/4" TRS jack to two male XLR plugs, one for the Right signal and one for the Left.

- Balanced mono circuits. When wired as a balanced connector, a 1/4" TRS jack or plug is connected tip to signal high (hot), ring to signal low (cold), and sleeve to ground (earth).
- Unbalanced Send/Return circuits. When wired as send/return "Y" connector, a 1/4" TRS jack or plug is connected tip to signal send (output from mixer), ring to signal return (input back into mixer), and sleeve to ground (earth).

1/4" TS Phone Plugs and Jacks

"TS" stands for Tip-Sleeve, the two connections available on a "mono" 1/4" phone jack or plug. See Figure C.

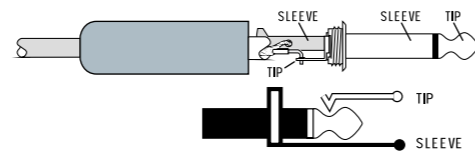

Figure C: TS Plug

TS jacks and plugs are used in many different applications, always unbalanced. The tip is connected to the audio signal and the sleeve to ground (earth). Some examples:

- Unbalanced microphones
- Electric guitars and electronic instruments
- Unbalanced line-level connections

Switched 1/4" Phone Jacks

Switches can be incorporated into 1/4" phone jacks, which are activated by inserting the plug. These switches may open an insert loop in a circuit, change the input routing of the signal or serve other functions. uses switches in the channel insert and bus insert jacks, input jacks and AUX returns. We also use these switches to ground the line-level inputs when nothing is plugged into them

In most cases, the plug must be inserted fully to activate the switch. Mackie takes advantage of this in some circuits, specifying circumstances where you are to insert the plug only partially. See Special Mackie Connections, on the next page.

Patchbay Description

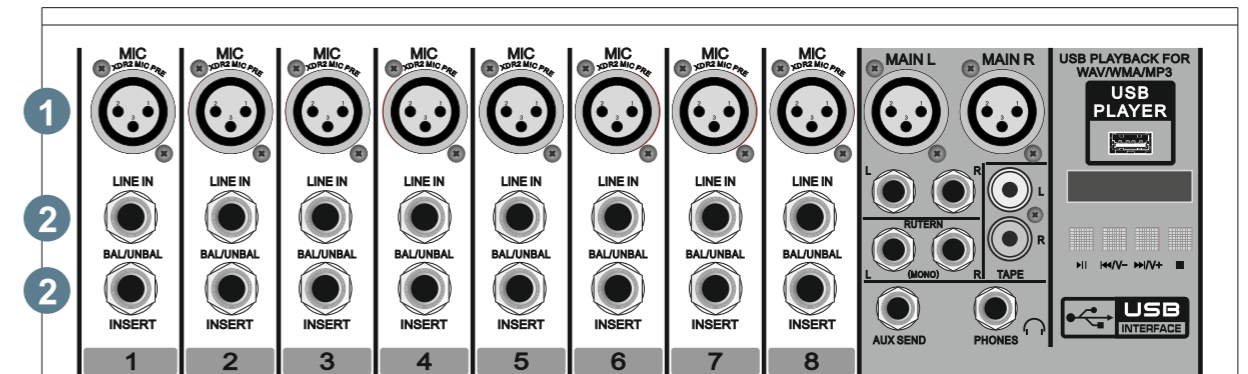

At the risk of stating the obvious, this is where you plug everything in: microphones, line-level instruments and effects, and the ultimate destination for your sound: a tape recorder, PA system, etc. Many of the features described in this section are on top of the mixer, but some are on the rear panel.

See Appendix B for further details and drawings of the connectors you can use with the mixer. Also see the Channel Strip description on page 12 for details of the signal routing from the XLR and Line inputs.

E-Z INTERFACING

Concerned about levels, balancing, impedances, polarity, or other interface goblins? Don't be. On your mixer, you can patch anything almost anywhere, with nary a care. Here's why.

- Every input and output is balanced (except inserts, phones and RCA jacks).
- Every input and output will also accept unbalanced lines (except XLR jacks).
- Every input is designed to accept virtually any output impedance.
- The main left and right mix outputs can deliver 28 dBu into as low as a 600 ohm load.
- All the other outputs can deliver 22 dBu into as low as a 600 ohm load.
- All the outputs are in phase with the inputs.

1. MIC INPUTS

We use phantom-powered, balanced microphone inputs just like the big studio mega- consoles, for exactly the same reason: This kind of circuit is excellent at rejecting hum and noise. You can plug in almost any kind of mic that has a standard XLR-type male mic connector. Always be sure to perform the Level-Setting Procedure. If you wire your own connectors, make them like this:

- Pin 1 = ground or shield
- Pin 2 = positive (+ or hot)
- Pin 3 = negative (- or cold)

Professional ribbon, dynamic, and condenser mics will all sound excellent through these inputs. The mic inputs will handle almost any kind of mic level you can toss at them, without overloading.

Not every instrument is made to connect directly to a mixer. Guitars commonly need a Direct Injection (DI) box to connect to the mixer's MIC inputs. These boxes convert unbalanced line-level signals from your guitar, into balanced mic-level outputs, and provide signal and impedance matching. They also let you send your gifted guitar renditions over long cables or audio snakes, with minimum interference and high-frequency signal loss. Ask your dealer or guitar maker about their recommendations for a good DI box.

PHANTOM POWER

Most condenser mics require phantom power, where the mixer sends low-current DC voltage to the mic's electronics through the same wires that carry audio. The phantom power is globally controlled by the PHANTOM switch on the rear panel.

Semipro condenser mics often have batteries to accomplish the same thing. "Phantom" owes its name to an ability to be "unseen" by dynamic mics that don't need external power and aren't affected by it.

Block Diagram

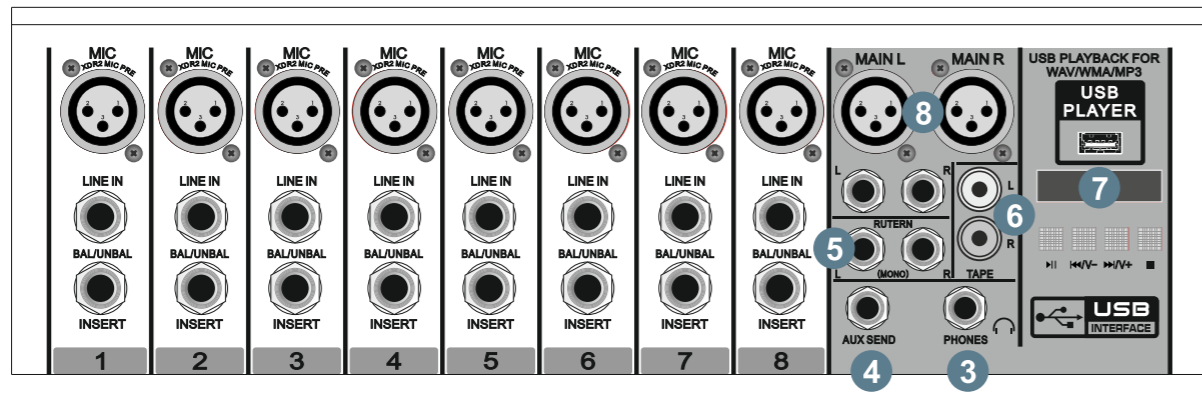

VERY IMPORTANT Unless you know for certain it is safe to do so, never plug single-ended (unbalanced) microphones, instruments, ribbon mics, or electronic devices into the MIC [1] input jacks if the phantom power is on.

2. LINE INPUTS

These 1/4" jacks share circuitry (but not phantom power) with the mic preamps. You can use these inputs for virtually any signal you'll come across, from instrument levels as low as -50 dB to operating levels of -10 dBV to +4 dBu, as there is 45 dB of gain available via the GAIN [4] knob. Note that channels 1-8 line inputs are initially attenuated by 15 dB.

Always be sure to perform the Level-Setting Procedure when you connect a new input.

To learn how signals are routed from these inputs, see the details lovingly described in the Channel Strip section.

3. PHONES

This 1/4" TRS stereo jack will drive any standard headphone to very loud levels. Walkperson-type phones can also be used with an appropriate adapter. If you're wiring your own cable for the PHONES output, follow standard conventions:

- Tip = Left channel
- Ring = Right channel
- Sleeve = Common ground

4. AUX SEND

These 1/4" TRS output connectors provide balanced or unbalanced line-level signals for connecting to the inputs of effects devices or stage monitor amplifiers.

5. AUX RETURNS

This is where you connect the output of your parallel effects devices (or extra audio sources). These balanced inputs the circuits will handle stereo or mono, balanced or unbalanced signals, either instrument level. They can be used with just about any pro or semipro effects device on the market. The switches coming into these inputs can be adjusted using the STEREO RETURN knobs before passing onto the main mix bus.

6. TAPE OUTPUT/REC

These unbalanced RCA connections tap the main mix output to make simultaneous recording and PA work more convenient. Connect these to your recorder's inputs.

Mono Out: If you want to feed a mono signal to your tape deck or other device, simply use an RCA Y-cord to combine these outputs. Do not attempt this with any other outputs on the mixer.

7. MP3 PLAYER

This procedure allows you to quickly play an mp3 song stored in the mass storage system(USB).

1. plug the USB cable in to your computer.
2. Push the Play/Pause button to play the first mp3 song of the mass storage medium. Led blinks during music play.
3. Next/Plus to change a music track or change a control level.
4. Repeat to Repeat the song is playing.

8. MAIN OUTPUTS

These line-level outputs connect the main mix to the outside world. Connect them to the balanced inputs of a power amplifier or powered speakers. See page 16 for details of the main mix.

These low-impedance outputs are fully balanced and capable of driving +4 dBu lines with up to 28 dB of headroom. This output is 6 dB hotter than other outputs.

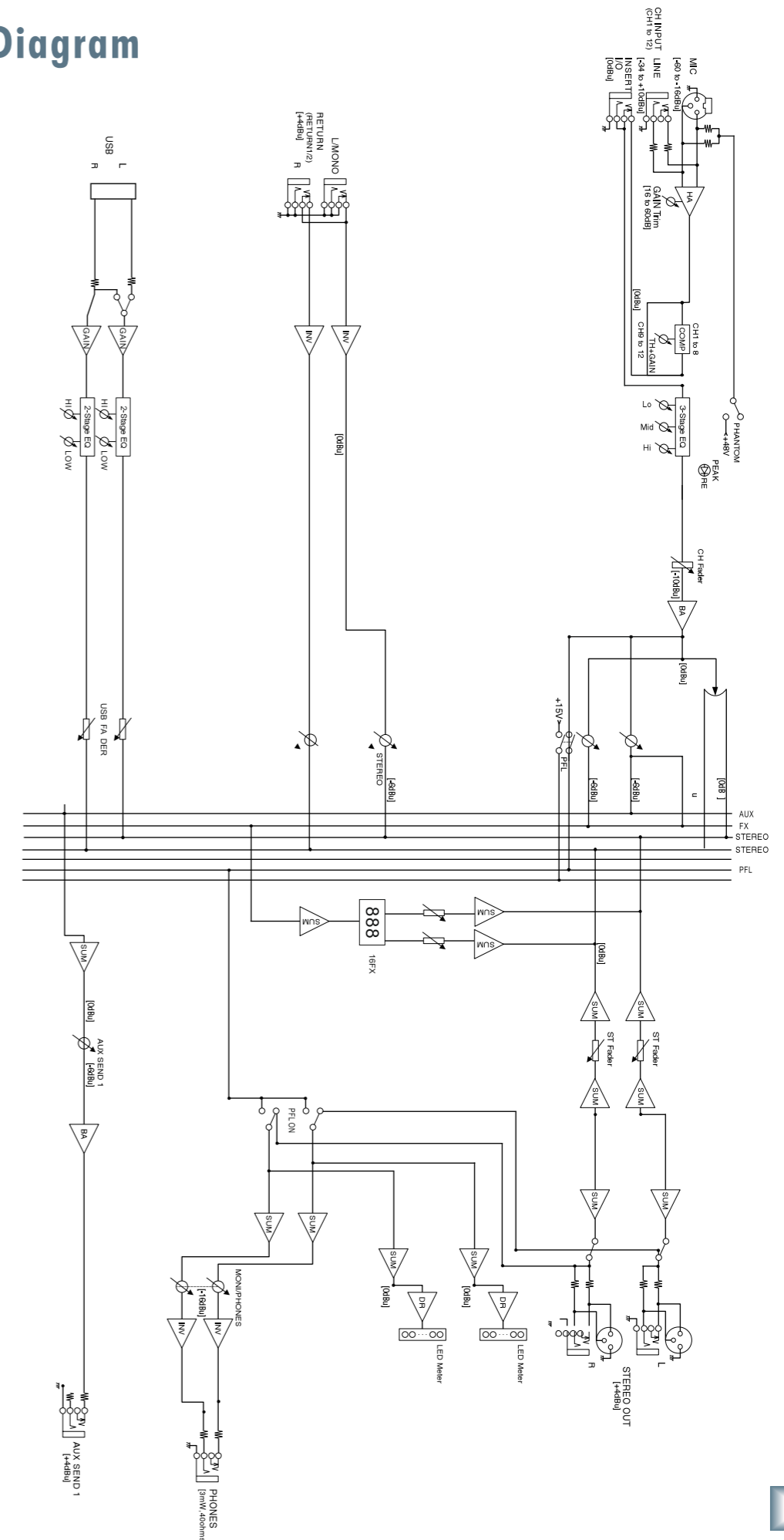

22. METERS

These meters have 2 columns of 10 LEDs each, with dB markings from -20 to +10, and OL (overload at +10 dBu). They indicate the stereo signal strength of the main mix after the main fader [31].

23. PHONES LEVEL

This controls the volume of the headphones output from off to maximum gain.

VERY IMPORTANT Warning: The headphone amplifier is designed to drive any standard headphones to a very loud level. It can cause permanent hearing damage. Even intermediate levels may be painfully loud with some headphones. Be careful! Always start with the phones level control turned all the way down before connecting headphones or making any connections. Keep it down until you've put on the headphones, and turn it down first whenever you play a new source or instrument.

24. USB PLAYER CHANNEL

This USB play channel are similar the mono channel.

25. USB FADER

These fader control the USB level from 0, to unity gain on up to 10 dB of additional.

26. DISPLAY

Please press the Rey stroke up and down, and it will be gotten the perfect neverberative effect that you need.

These function which has (16) effective posture can be turned up.

27. REPEAT

This knob is used for adjusting frequency of echo repeat. Since too much echo repeat may cause a howl. Please adjust frequency properly.

28. AUX SEND

This control adjusts the signal level sent to the AUX SEND jack.

29. AUX RETURN

These control set the overall level of effects received from the RETURNS [13] input jacks.

30. FX RETURN FADER

Use this fader to gently adjust the level of the stereo output from the internal FX processor being added to the main mix. The range is off to +10 dB with unity at "U".

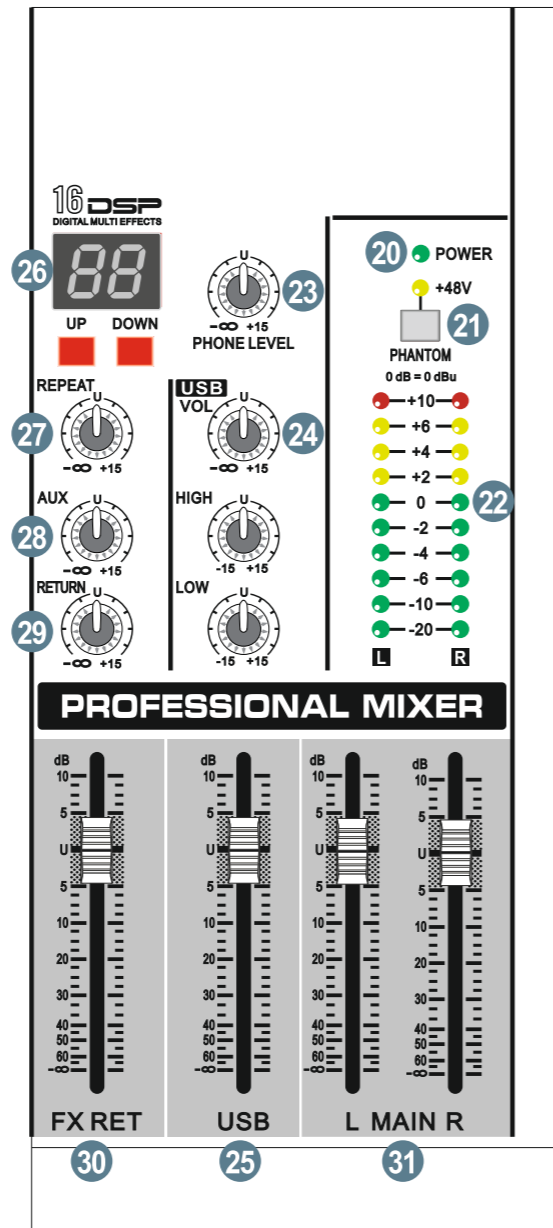

31. LEFT / RIGHT MAIN FADER

These faders control the level of the main mix and effects the mators and main line-level outputs.

They give you ultimate control over the audience.

Adjust it carefully, with a good eye on the mators to check against overloading and a good ear on the levels to make sure the audience is happy.

The main mix signals are off with the fader fully down, the "U" marking is unity gain and fully up provides 10 dB of additional gain. This additional gain will know it's there.

The level control is stereo, as it affects both the left and right of the main mix equally.

This is the control to turn down at the end of the song when you want "The Great Fade-Out."

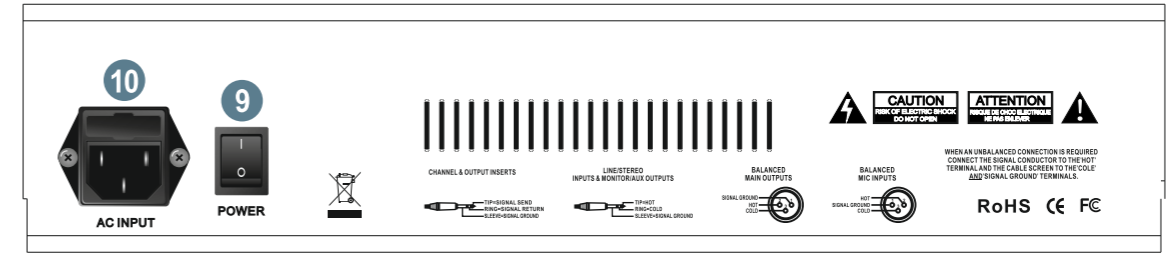

9. POWER SWITCH

Press the top of this rocker switch inwards to turn on the mixer. The POWER LED on the top surface of the mixer will glow with happiness, or at least it will if you have the mixer plugged in to a suitable live AC mains supply.

Press the bottom of this switch to turn off the mixer, whenever you feel that this would be a safe thing to do.

10. POWER CONNECTION

Just in case you lose the cord provided with the mixer, its power jack accepts a standard 3-prong IEC cord like those found on most professional recorders musical instruments, and computers.

VERY IMPORTANT WARNING: Disconnecting the plug's ground pin can be dangerous. Please don't do it.

Channel Strip Description

Mono Channels

- The mono channel controls affect both the mono mic input and the mono line-level input.
- The gain knob adjust both mic and line input.
- Each mono channel has an insert jack and low cut switch.
- Channel 1 has a hi-z switch to connect a guitar directly.
- The 3-band EQ has shelving high, shelving low, and peaking mid EQ.

"U" LIKE UNITY GAIN

Theye mixers have a "U" symbol on almost every level control. This "U" stands for "unity gain," meaning no change in signal level (0 dB gain). Once you have adjusted the input signal with the gain control, set every control at "U" and the signals will travel through the mixer at optimal levels. What's more, all the labels on our levels cotrols are measured in decibels (dB), so you'll know what you're doing levels-wise if you choose to change a control's setting.

11. GAIN

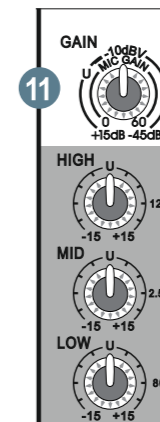

These controls are not in the patchbay, but they are the top row of knobs in the channel strip section. (They are so vitally linked with the inputs, this seemed like a good place to describe them)

Every time you plug something into a MIC [1] or LINE [2] input jack, you should perform the Level-Setting Procedure, and that procedure is basically "how to use the GAIN knob."

GAIN adjusts the input sensitivity of the MIC and LINE inputs. This allows signals from the outside world to be adjusted to optimal internal operating levels.

Through the XLR jack (MIC), there will be 0 dB of gain with the knob fully down, ramping to 60 dB of gain fully up.

Through the 1/4" input (LINE), there is 15 dB of attenuation fully down and 45 dB of gain fully up, with unity gain (U) at 10:00.

This 15 dB of attenuation can be very handy when you are inserting a signal that is very hot, or you want to add a lot of EQ gain, or both. Without this "virtual pad," a scenario like this might lead to channel clipping.



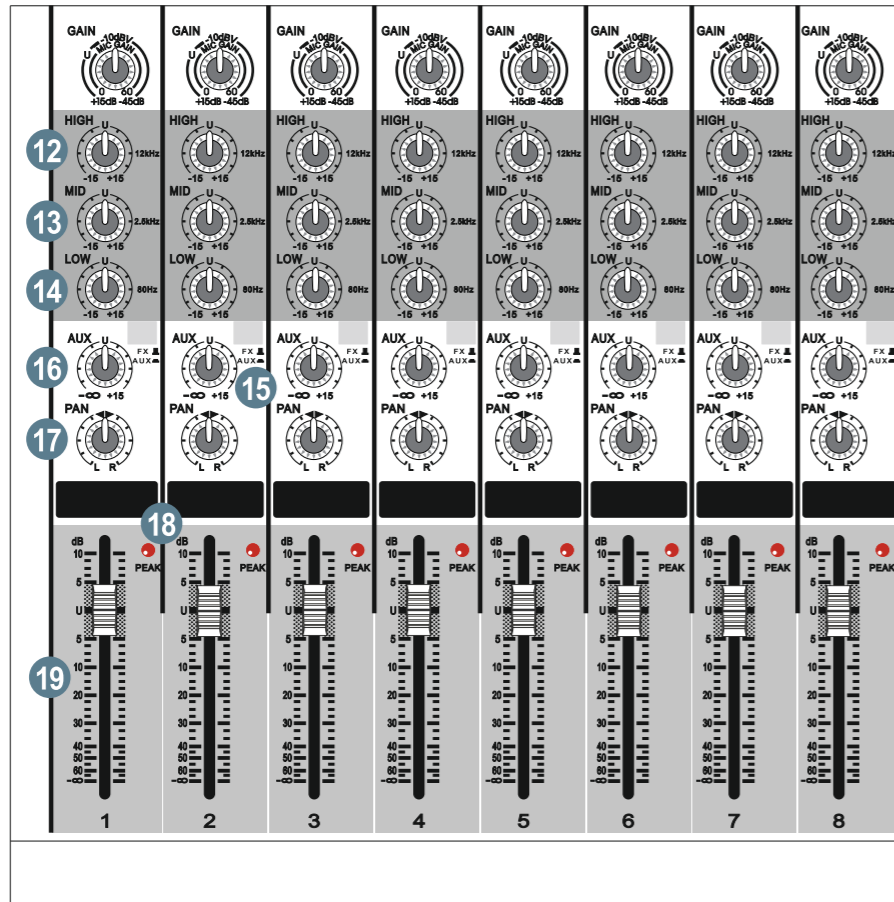

12. HI EQ

This control gives you up to 15 dB boost or cut above 12kHz, and it is flat (no boost or cut) at the detent. Use it to add sizzle to cymbals, and an overall sense of transparency, or edge to keyboards, vocals, guitar and bacon frying. Turn it down a little to reduce sibilance, or to hide tape hiss.

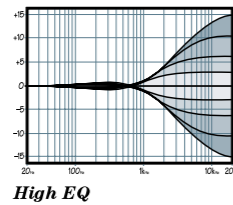

13. MID EQ

Short for “midrange,” this knob provides 15 dB of boost or cut, centered at 2.5 kHz, also flat at the center detent. Midrange EQ is often thought of as the frequencies that define any particular sound are almost always found in this range. You can create many interesting and useful EQ changes by turning this knob down as well as up.

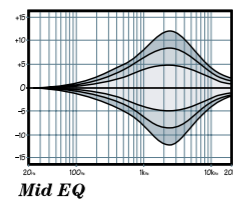

14. LOW EQ

This control gives you up to 15 dB boost or cut below 80 Hz. The circuit is flat at the center detent position. This frequency represents the punch in bass drums, bass guitar, fat synth patches, and some really serious male singers.

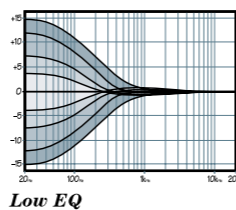

Used in conjunction with the low cut switch, you can boost the low EQ without injecting a ton of subsonic debris into the mix.

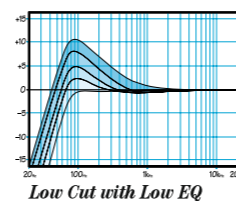

15. AUX/ FX

This switch is used to select whether the AUX signal assign to the FX bus or the AUX send bus.

16. AUX

These tap a portion of each channel’s signal out to an effects processor or for stage monitoring. The AUX send levels are controlled by the channel’s AUX 1-3 knobs, and by the AUX SEND MASTERS knobs.

17. PAN

These knobs adjust the amount of channel signal sent to the left versus the right outputs. On mono channels these controls act as pan pots. On hybrid and stereo channels, they work like the balance control on a home stereo. They do not affect the aux mon or FX mixes.

18. PEAK (PEAK LEVEL INDICATOR)

A red LED indicates a signal level at the insert return point, pre master fader. It illuminates at approximately 5dB below clipping.

19. CHANNEL FADER

These faders control the channel’s level from off, to unity gain, on up to 10 dB of additional gain. The mono channels have mono faders, and the hybrid and stereo channels use stereo faders.

With the gain control [16] set correctly, the faders should be set around unity gain (U).

Master Controls Description

20. POWER LED

This LED comes on when the mixer is plugged into the AC mains supply, and the rear panel power switch [10] is on.

If the LED does not turn on, make sure the AC power is live, both ends of the power cord are correctly inserted, the electricity bill has been paid and the lights in town are on.

21. PHANTOM POWER SWITCH

If the microphones need phantom power, press in this switch to add phantom power to all the XLR microphone inputs of the mixer. This lets the mixer send low-current DC voltage to the mic’s electronics through the same wires that carry audio. The LED will turn on as a reminder that phantom power is engaged.

